

Compact Tester for Li-Ion Battery Cells



When testing and optimizing Li-Ion battery cell properties, the cells must be inspected for their electrical, electrochemical and thermal properties. During testing, many hazards may exist from the cells that can be classified according to EUCAR Hazard Levels 0 – 7.

Using the compact test system, individual battery cells from hazard levels 0 to 7 can be tested. Flexible software allows the creation of your own test cycles. The system can also be expanded to include impedance measurements.

With its modular design, the cell test system can be easily connected to several test systems. We would be pleased to integrate the cell tester into a safety housing for you or directly into your laboratory environment.

We also offer the connection of the cell test system to a host computer. This ensures consistency and safety in your test programs and results. The Compact tester – a turnkey test system for Li-Ion cells that can safely handle even unsafe test pieces.

best testing – best quality

moehwald
Bosch Group

Compact Tester for Li-Ion Battery Cells

Technical Data

Test piece	Li-Ion battery cell	Compact tester dimensions	970 x 1400 x 2080 mm (W x D x H)
Permissible hazards	Hazard level 0 to 7, from hazard level 4 setup in insulated fire protection area required	Protection class	IP54
Test chamber volume	approx. 65 liters	Voltage range	0 to 6 V (other voltages on request)
Test chamber interior dimensions	490 x 395 x 340 mm (W x D x H)	Current range	0 to 400 A
Temperature range	-50° C to +120° C	Accuracy	±0,05% of measured value ±0,01% of measured range
Permissible heat irradiation	max. 500 W at - 40° C	Data interface	Ethernet

Principle Circuit Diagramm

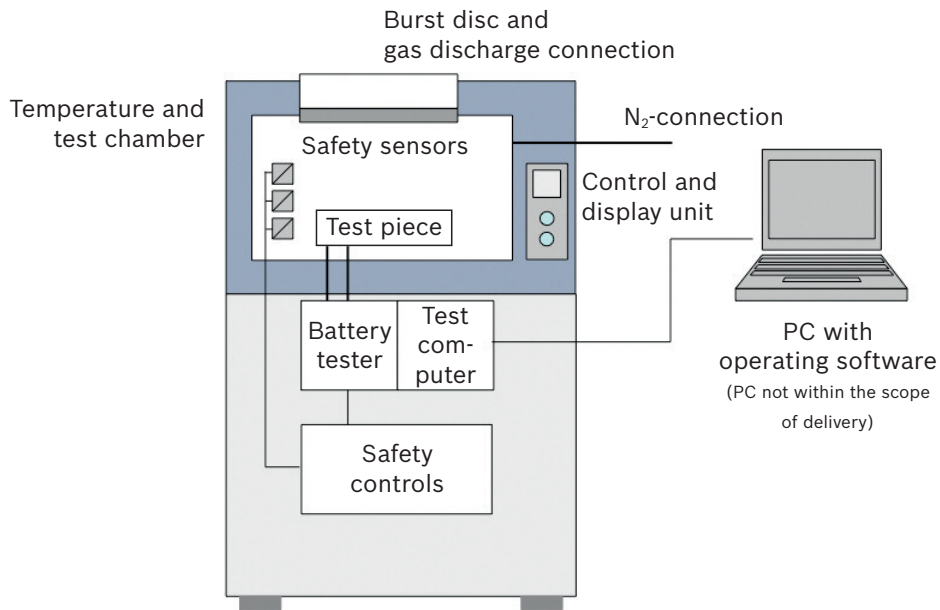

These documents are a principle description and not an operating manual. Individual deviations in the description may exist compared to the operating manual. Proper implementation of the system must be carried out using the operating manual.

Contact Moehwald:

Gerd Wagner · Phone +49 6841-707-233
email: g.wagner@moehwald.de
www.moehwald.de

moehwald
Bosch Group